

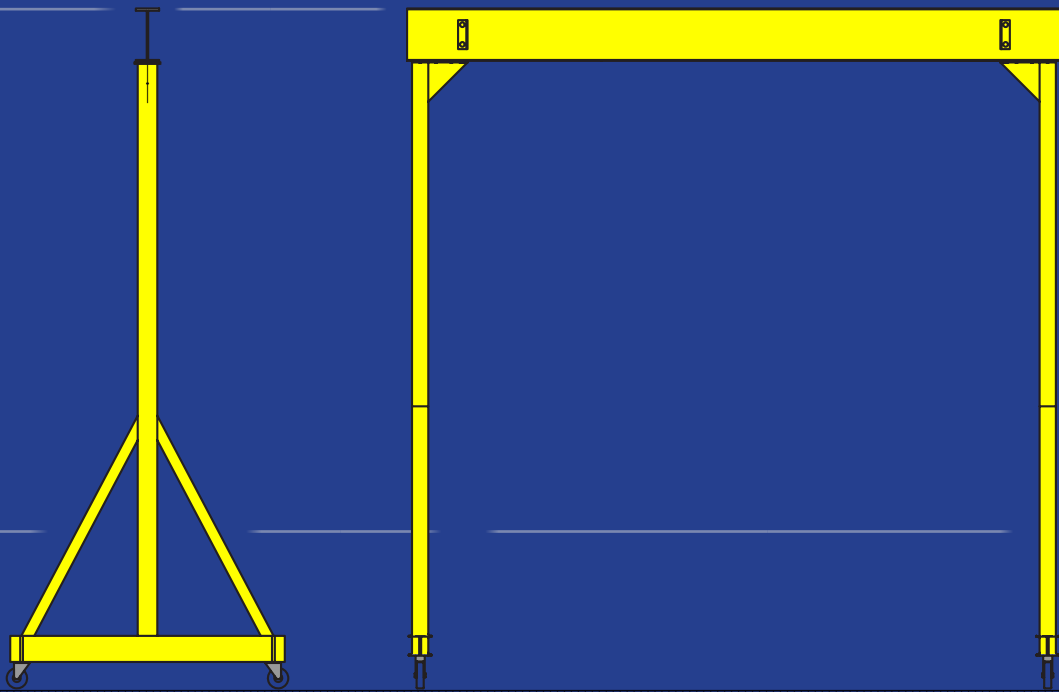

# Gantry Crane

## Fixed Height



# Specifications

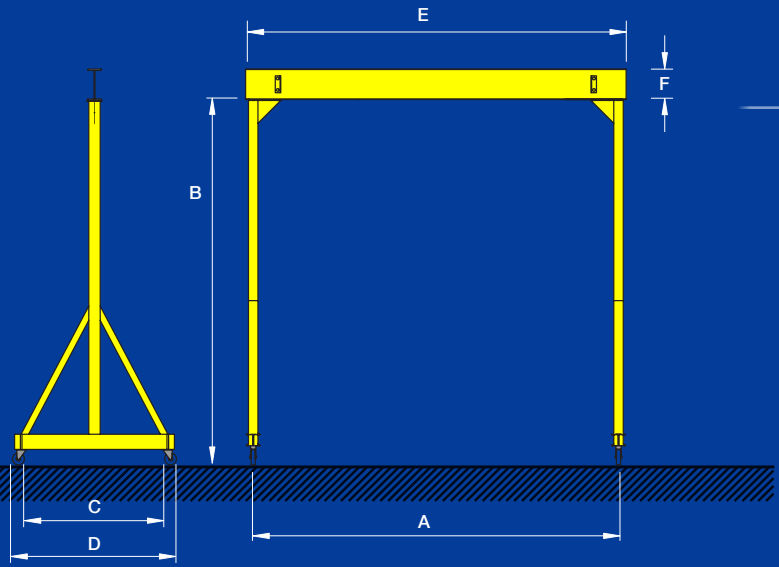

Model	Capacity [tons]	Span A	Height B	C	D	E	F	Shipping Weight [Approx. lbs.]	
1TFHG-10-10	1 Ton	10'	10'	36"	41"	11' 3"	8"	700	
1TFHG-10-12			12'	42"	47"	11' 3"	8"	750	
1TFHG-10-15			15'	48"	53"	11' 3"	8"	810	
1TFHG-10-10		12'	12'	10'	36"	41"	13' 3"	8"	740
1TFHG-10-12				12'	42"	47"	13' 3"	8"	790
1TFHG-10-15				15'	48"	53"	13' 3"	8"	850
1TFHG-10-10		15'	15'	10'	36"	41"	16' 3"	10"	900
1TFHG-10-12				12'	42"	47"	16' 3"	10"	940
1TFHG-10-15				15'	48"	53"	16' 3"	10"	1000
1TFHG-10-10		20'	20'	10'	36"	41"	21' 3"	10"	1025
1TFHG-10-12				12'	42"	47"	21' 3"	10"	1070
1TFHG-10-15				15'	48"	53"	21' 3"	10"	1130
2TFHG-10-10	2 Ton	10'	10'	36"	43"	11' 3"	8"	800	
2TFHG-10-12			12'	42"	49"	11' 3"	8"	870	
2TFHG-10-15			15'	48"	55"	11' 3"	8"	970	
2TFHG-10-10		12'	12'	10'	36"	41"	13' 3"	8"	840
2TFHG-10-12				12'	42"	47"	13' 3"	8"	910
2TFHG-10-15				15'	48"	53"	13' 3"	8"	1000
2TFHG-10-10		15'	15'	10'	36"	43"	16' 3"	10"	1020
2TFHG-10-12				12'	42"	49"	16' 3"	10"	1060
2TFHG-10-15				15'	48"	55"	16' 3"	10"	1150
2TFHG-10-10		20'	20'	10'	36"	43"	21' 3"	10 1/2 "	1356
2TFHG-10-12				12'	42"	49"	21' 3"	10 1/2 "	1430
2TFHG-10-15				15'	48"	55"	21' 3"	10 1/2 "	1525
3TFHG-10-10	3 Ton	10'	10'	36"	44"	11' 3"	10"	890	
3TFHG-10-12			12'	42"	50"	11' 3"	10"	925	
3TFHG-10-15			15'	48"	56"	11' 3"	10"	980	
3TFHG-12-10		12'	12'	10'	36"	41"	13' 3"	8"	945
3TFHG-12-12				12'	42"	47"	13' 3"	8"	980
3TFHG-12-15				15'	48"	53"	13' 3"	8"	1040

Continued on next page →

# Gantry Crane Fixed Height

## Specifications (cont.)

Model	Capacity [tons]	Span A	Height B	C	D	E	F	Shipping Weight [Approx. lbs.]	
3TFHG-15-10	3 Ton	15'	10'	36"	44"	16' 3"	12"	1030	
3TFHG-15-12			12'	42"	50"	16' 3"	12"	1070	
3TFHG-15-15			15'	48"	56"	16' 3"	12"	1125	
3TFHG-20-10		20'	10'	36"	44"	21' 3"	15"	1525	
3TFHG-20-12			12'	42"	50"	21' 3"	15"	1575	
3TFHG-20-15			15'	48"	56"	21' 3"	15"	1645	
5TFHG-10-10	5 Ton	10'	10'	36"	44"	11' 4"	12"	1620	
5TFHG-10-12			12'	42"	50"	11' 4"	12"	1685	
5TFHG-10-15			15'	48"	56"	11' 4"	12"	1800	
5TFHG-12-10		12'	10'	36"	44"	13' 4"	12"	1725	
5TFHG-12-12			12'	42"	50"	13' 4"	12"	1800	
5TFHG-12-15			15'	48"	56"	13' 4"	12"	1915	
5TFHG-15-10		15'	10'	36"	44"	16' 4"	15"	1900	
5TFHG-15-12			12'	42"	50"	16' 4"	15"	1970	
5TFHG-15-15			15'	48"	56"	16' 4"	15"	2075	
5TFHG-20-10		20'	10'	36"	44"	21' 4"	15 ½ "	2180	
2TFHG-20-12			12'	42"	50"	21' 4"	15 ½ "	2255	
5TFHG-20-15			15'	48"	56"	21' 4"	15 ½ "	2370	
10TFHG-10-10		10 Ton	10'	10'	36"	45"	11' 5"	18"	2290
10TFHG-10-12				12'	42"	51"	11' 5"	18"	2440
10TFHG-10-15				15'	48"	57"	11' 5"	18"	2660
10TFHG-12-10	12'		10'	36"	45"	13' 5"	18"	2405	
10TFHG-12-12			12'	42"	51"	13' 5"	18"	2550	
10TFHG-12-15			15'	48"	57"	13' 5"	18"	2775	
10TFHG-15-10	15'		10'	36"	45"	16' 5"	20"	2575	
10TFHG-15-12			12'	42"	51"	16' 5"	20"	2725	
10TFHG-15-15			15'	48"	57"	16' 5"	20"	2945	
10TFHG-20-10	20'		10'	36"	45"	21' 5"	20 ½ "	2860	
10TFHG-20-12			12'	42"	51"	21' 5"	20 ½ "	3010	
10TFHG-20-15			15'	48"	57"	21' 5"	20 ½ "	3230	

\*Dimensions may be subject to change at time of order based on material available.

All our gantry cranes have been manufactured by our parent company The Dressor Group Ltd. Dressor is a CWB certified welding company certified to CSA W 59 and all gantries are welded to CSA W47.1 and are pre-engineered to the highest possible standards including a 15% impact allowance for an electric hoist.

Unless otherwise specified, all gantry cranes come with four swivel castors, two of them with a locking brake.



Distributed by:

